

CONFIDENTIAL

THIS DOCUMENT AND INFORMATION CONTAINED HEREIN IS PROPRIETARY AND CONFIDENTIAL TO PRECOR STRENGTH INCORPORATED. RECIPIENTS OF THIS DOCUMENT AGREE THAT THIS DOCUMENT AND INFORMATION WILL NOT BE USED FOR ANY PURPOSE, REPRODUCED OR COPIED, OR DISCLOSED TO ANY THIRD PARTY, EITHER IN WHOLE OR IN PART WITHOUT PRIOR EXPRESS WRITTEN PERMISSION OF PRECOR STRENGTH, INCORPORATED.

PRECOR USA
PRECOR STRENGTH, INC.

28936 AVE WILLIAMS
VALENCIA, CA 91355
TELEPHONE: 661-362-0300

SIGN IN BLUE OR BLACK INK ONLY		
DRWN BY	01.02.07	MGP
DWG CHK		
ENG	01.02.07	RSG
MPG ENG		
CS		
QA		
ID		
REG		

UNLESS OTHERWISE SPECIFIED:
DIMENSIONS ARE IN INCHES
TOLERANCES ARE:
LIN .X=±0.1 .XXX=±0.010
LIN .XX=±0.02 .XXXX=±0.0001
ANGULAR: ±1.0°
ALL DIMS AFTER PLATING
BREAK ALL SHARP EDGES
REMOVE ALL BURRS
ALL ANGLES & BENDS 90°
DWG PER ASME Y14.5M-1994
DO NOT SCALE DRAWING
ALL MACHINED SURFACES

PRODUCT:		STRENGTH
ASSEMBLY CONNECTION, 10.5, W/ 1 PULLEY HSG		
DWG. NO.	CW31868-402	SUBREV A

SIZE	PAGE	OF
C	1	1

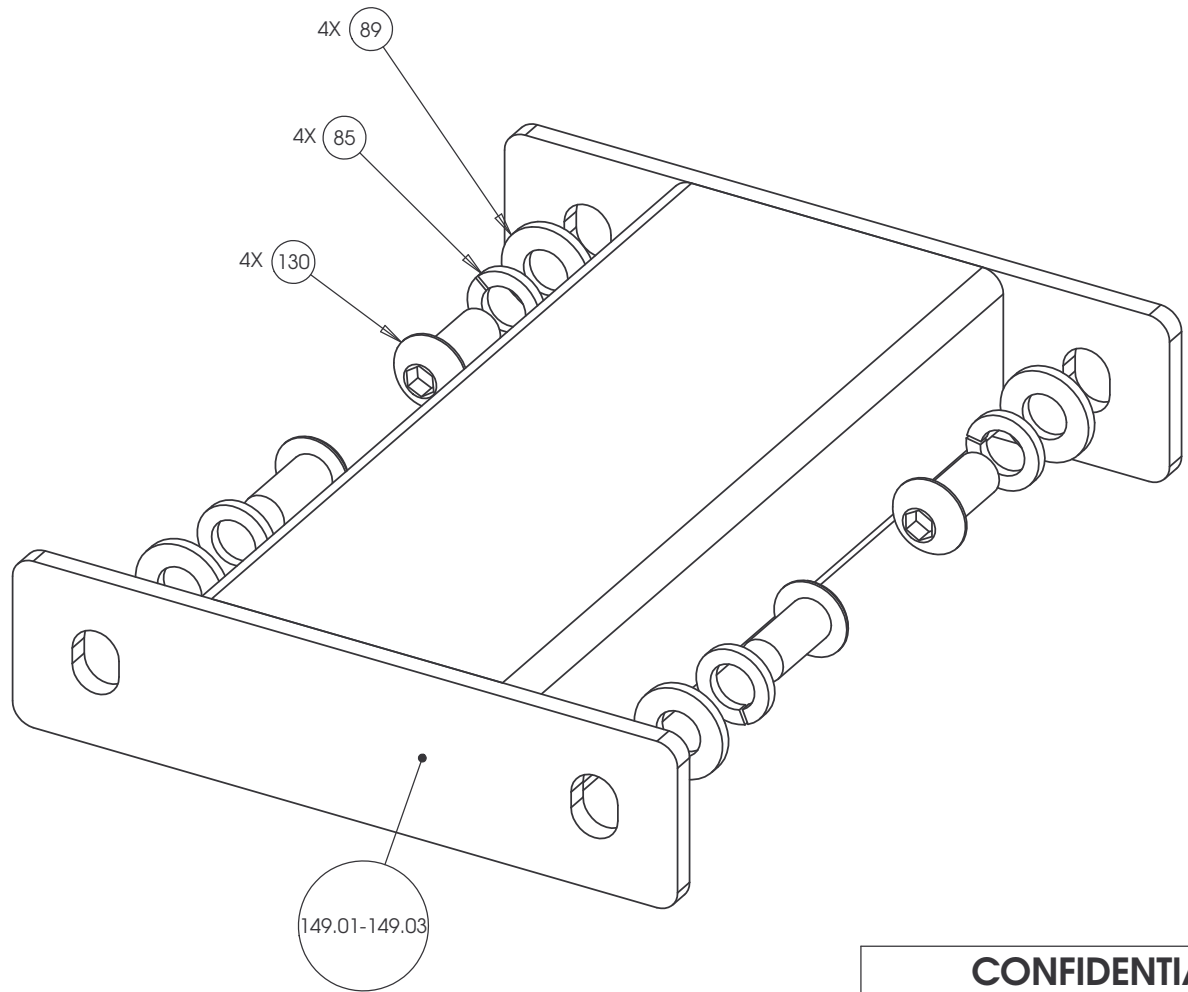

CONFIDENTIAL

THIS DOCUMENT AND INFORMATION CONTAINED HEREIN IS PROPRIETARY AND CONFIDENTIAL TO PRECOR STRENGTH INCORPORATED. RECIPIENTS OF THIS DOCUMENT AGREE THAT THIS DOCUMENT AND INFORMATION WILL NOT BE USED FOR ANY PURPOSE, REPRODUCED OR COPIED, OR DISCLOSED TO ANY THIRD PARTY, EITHER IN WHOLE OR IN PART WITHOUT PRIOR EXPRESS WRITTEN PERMISSION OF PRECOR STRENGTH, INCORPORATED.

PRECOR USA
PRECOR STRENGTH, INC.

28936 AVE WILLIAMS
VALENCIA, CA 91355
TELEPHONE: 661-362-0300

SIGN IN BLUE OR BLACK INK ONLY			UNLESS OTHERWISE SPECIFIED: DIMENSIONS ARE IN INCHES			PRODUCT:	
DRWN BY	08.15.06	VLE	TOLERANCES ARE:			STRENGTH	
DWG CHK			LIN	.X=±0.1	.XXX=±0.010	ASSEMBLY CONNECTION, 10.5	
ENG	06.19.06	RSG	LIN	.XX=±0.02	.XXXX=±0.0001		
MFG ENG			ANGULAR: ±1.0°				
CS			ALL DIMS AFTER PLATING				
QA			BREAK ALL SHARP EDGES				
ID			REMOVE ALL BURRS			DWG. NO.	
REG			ALL ANGLES & BENDS 90°*			SUBREV	
			DWG PER ASME Y14.5M-1994			CW31874-402	
			DO NOT SCALE DRAWING			A	
			ALL MACHINED SURFACES				
			SIZE	PAGE	OF		
			C	1	1		

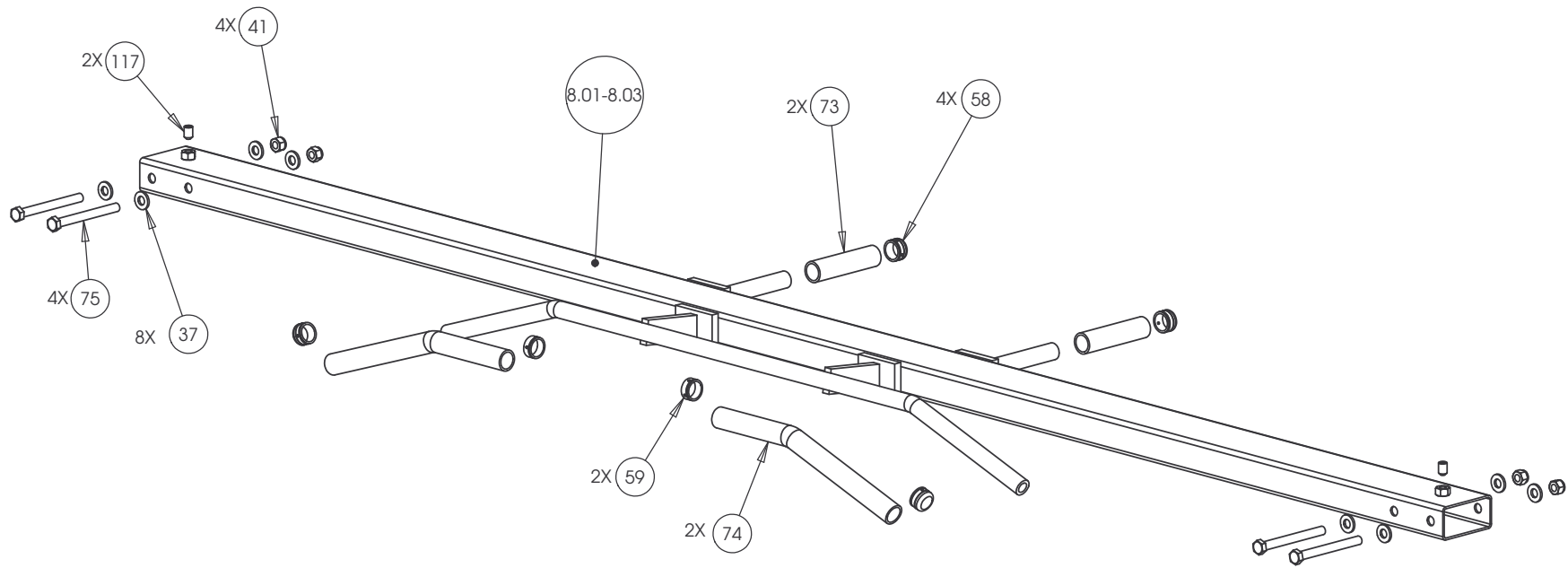

CONFIDENTIAL

THIS DOCUMENT AND INFORMATION CONTAINED HEREIN IS PROPRIETARY AND CONFIDENTIAL TO PRECOR STRENGTH INCORPORATED. RECIPIENTS OF THIS DOCUMENT AGREE THAT THIS DOCUMENT AND INFORMATION WILL NOT BE USED FOR ANY PURPOSE, REPRODUCED OR COPIED, OR DISCLOSED TO ANY THIRD PARTY, EITHER IN WHOLE OR IN PART WITHOUT PRIOR EXPRESS WRITTEN PERMISSION OF PRECOR STRENGTH, INCORPORATED.

PRECOR USA
PRECOR STRENGTH, INC.

28936 AVE WILLIAMS
VALENCIA, CA 91355
TELEPHONE: 661-362-0300

SIGN IN BLUE OR BLACK INK ONLY			UNLESS OTHERWISE SPECIFIED: DIMENSIONS ARE IN INCHES		PRODUCT: STRENGTH
DRWN BY	01.02.07	MGP	TOLERANCES ARE: LIN .X=±0.1 .XXX=±0.010 LIN .XX=±0.02 .XXXX=±0.0001		
DWG CHK			ANGULAR: ±1.0°		ASSEMBLY CONNECTION, 107 IN, CROSSBEAM W-HANDLES
ENG	01.02.07	RSG	ALL DIMS AFTER PLATING BREAK ALL SHARP EDGES REMOVE ALL BURRS		
MFG ENG			ALL ANGLES & BENDS 90°		
CS			DWG PER ASME Y14.5M-1994		
QA			DO NOT SCALE DRAWING		
ID			ALL MACHINED SURFACES		
REG			SIZE	PAGE OF	DWG. NO.
			C	1 1	CW31878-401
					SUBREV A

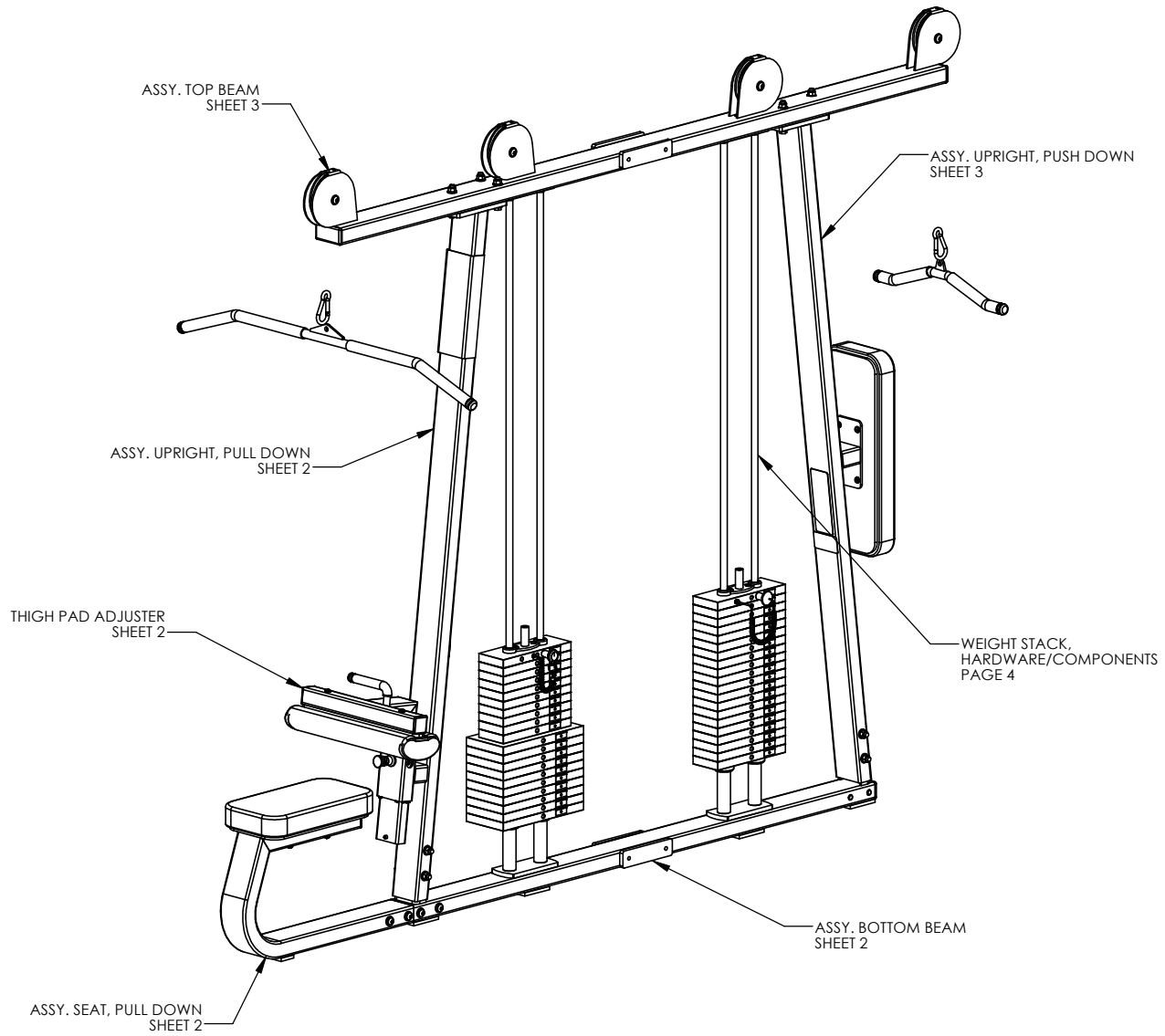

P/N: CW31927-402	SUBREV: E
DRAWN BY: VLE	DATE: 08.18.09
SHEET 1 OF 4	

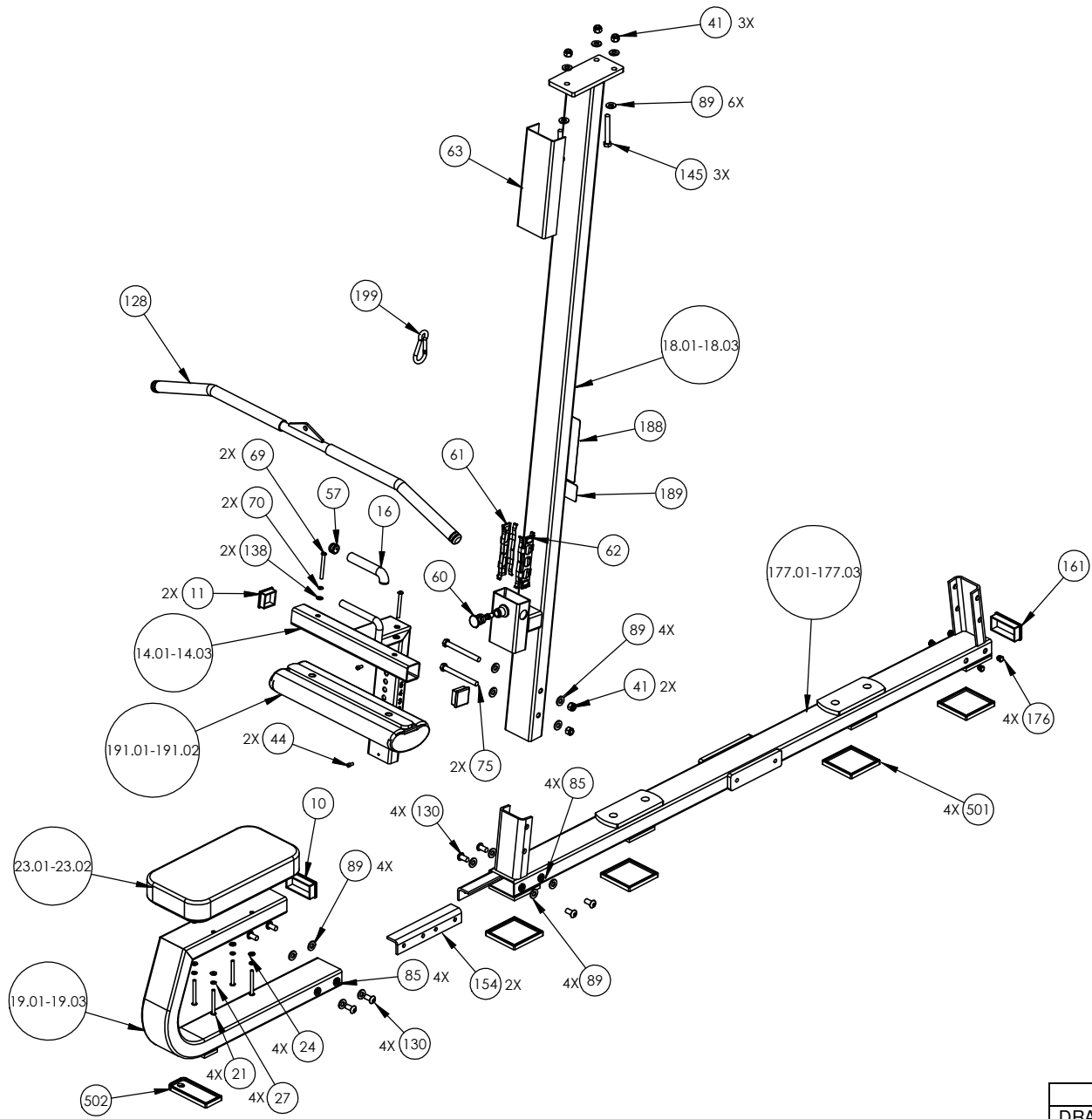

P/N: CW31927-402		SUBREV: E	
DRAWN BY: VLE	DATE: 08.18.09	SHEET 2 OF 4	

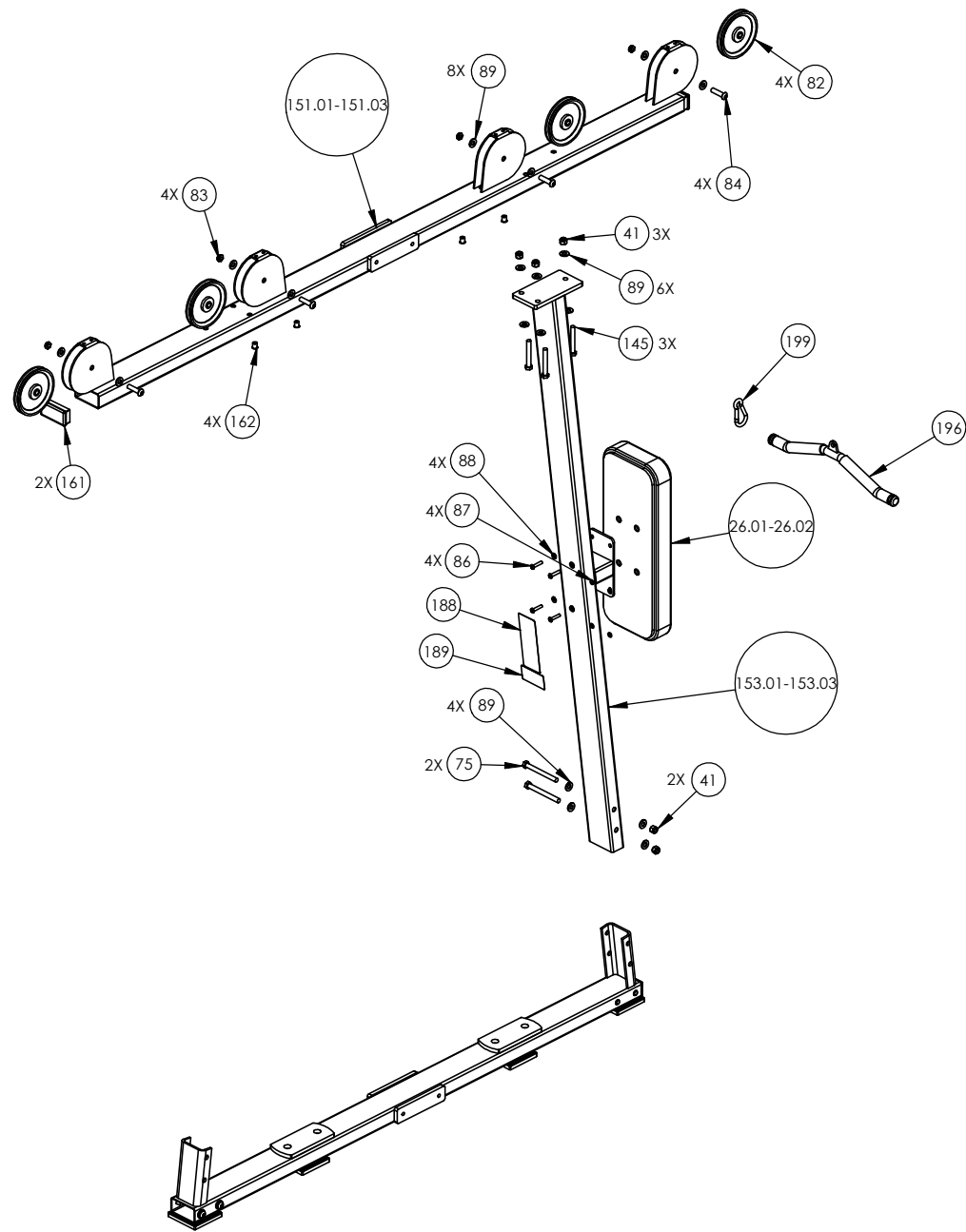

P/N: CW31927-402	SUBREV: E
DRAWN BY: VLE	DATE: 08.18.09
SHEET 3 OF 4	

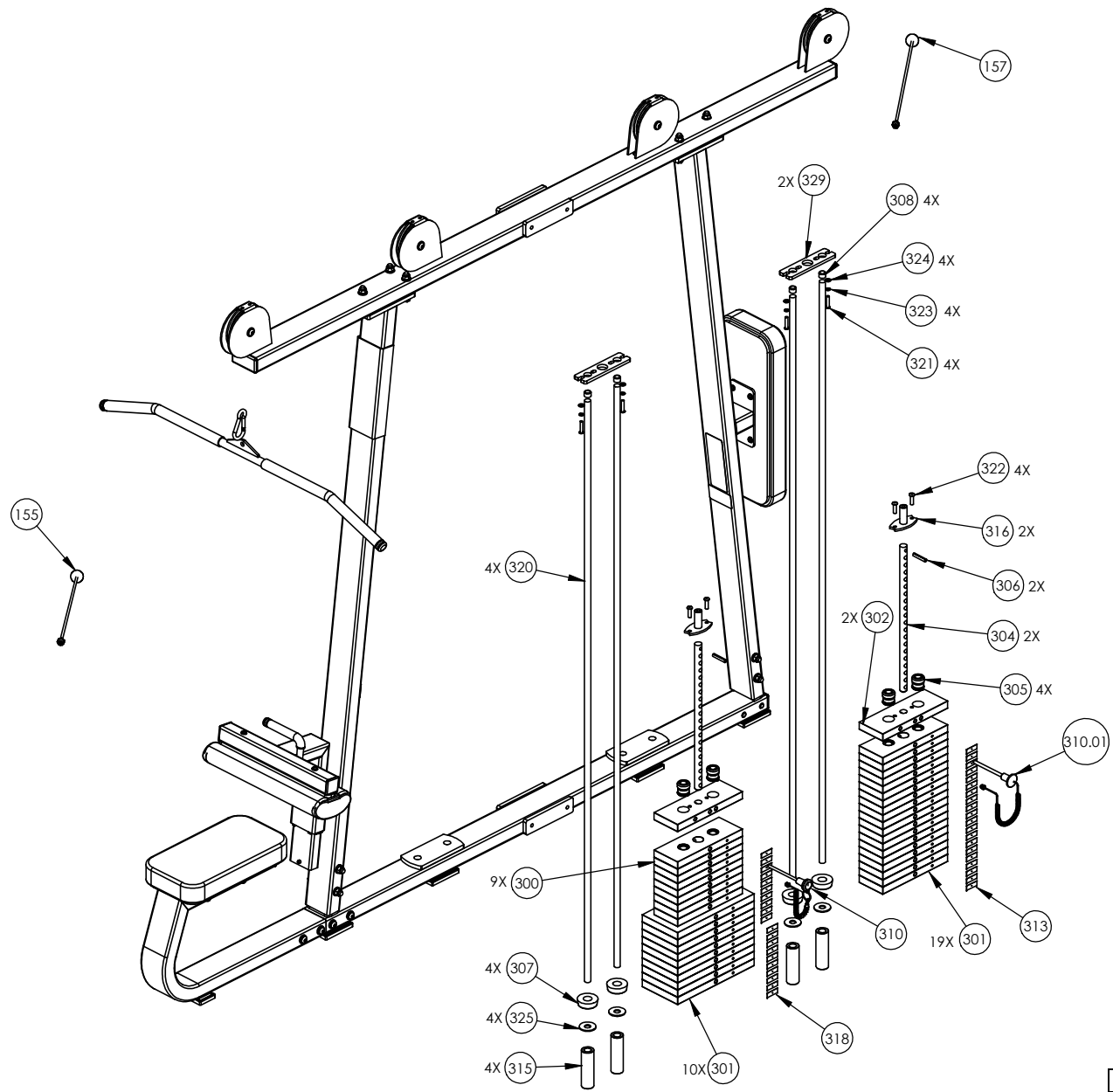

P/N: CW31927-402	SUBREV: E
DRAWN BY: VLE	DATE: 08.18.09
SHEET 4 OF 4	

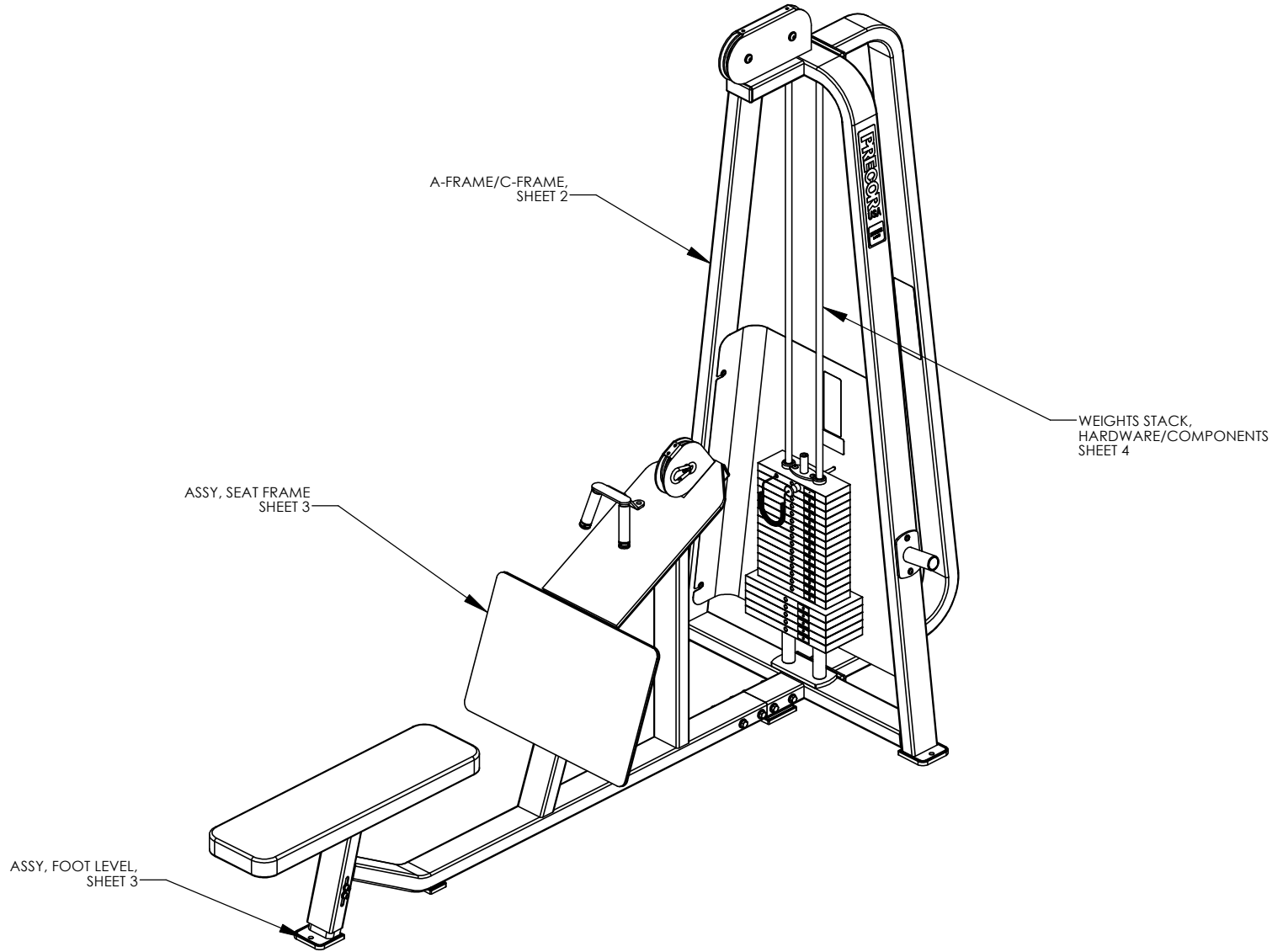

P/N: CW31931-402	SUBREV: C
DRAWN BY: JEC	DATE: 09.11.08
	SHEET 1 OF 4

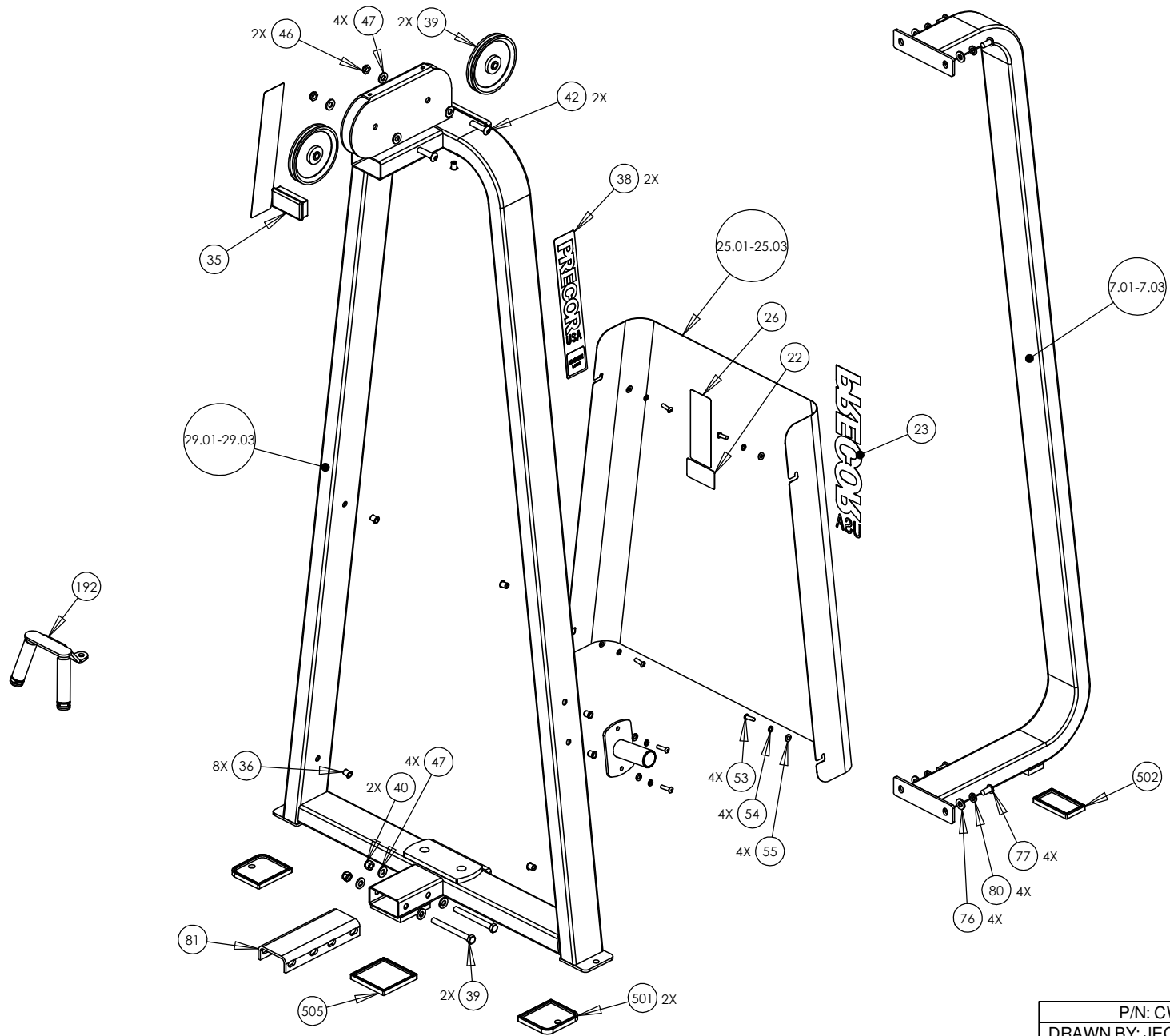

P/N: CW31931-402	SUBREV: C
DRAWN BY: JEC	DATE: 09.11.08
SHEET 2 OF 4	

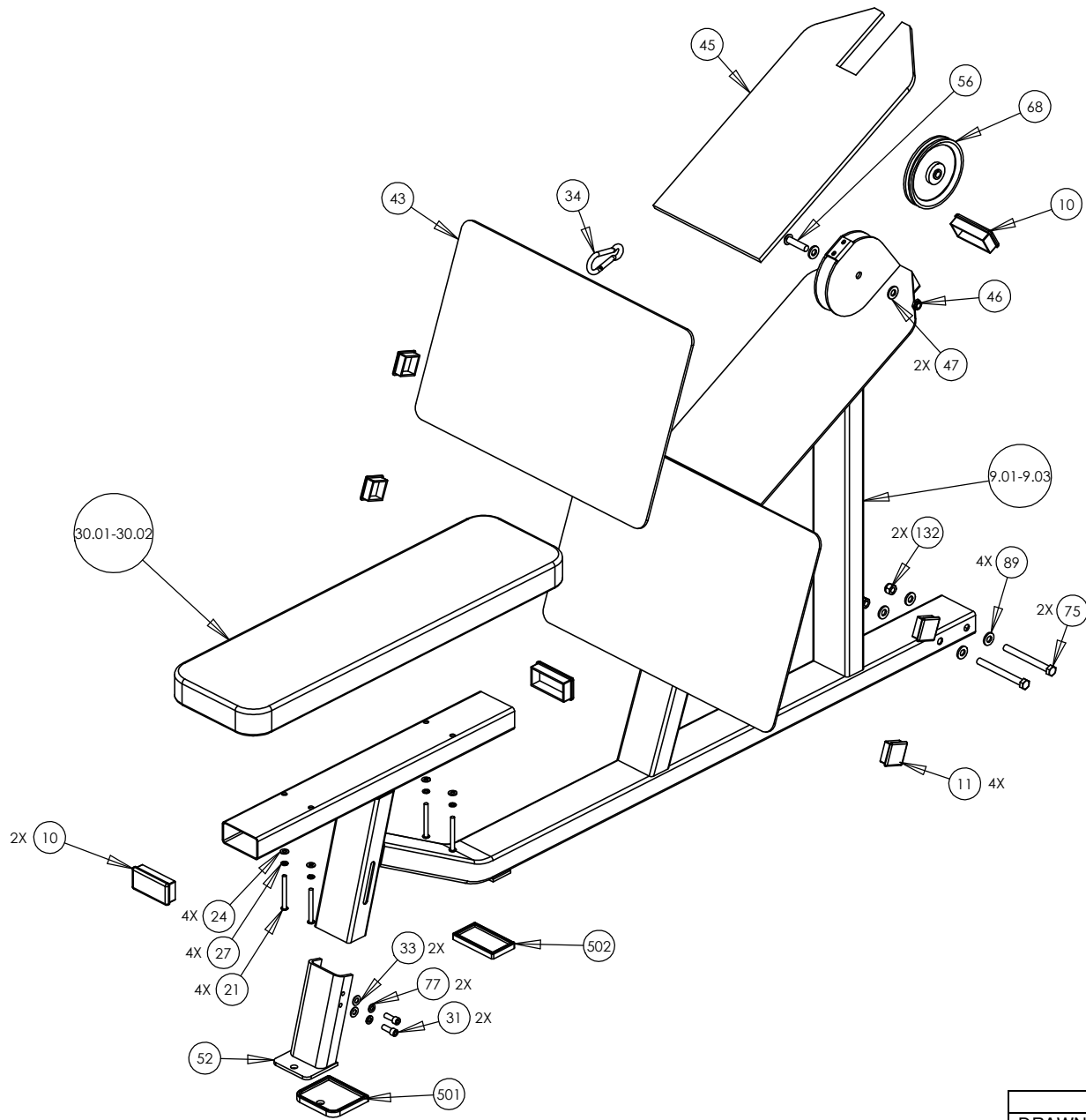

P/N: CW31931-402		SUBREV: C
DRAWN BY: JEC	DATE: 09.11.08	SHEET 3 OF 4

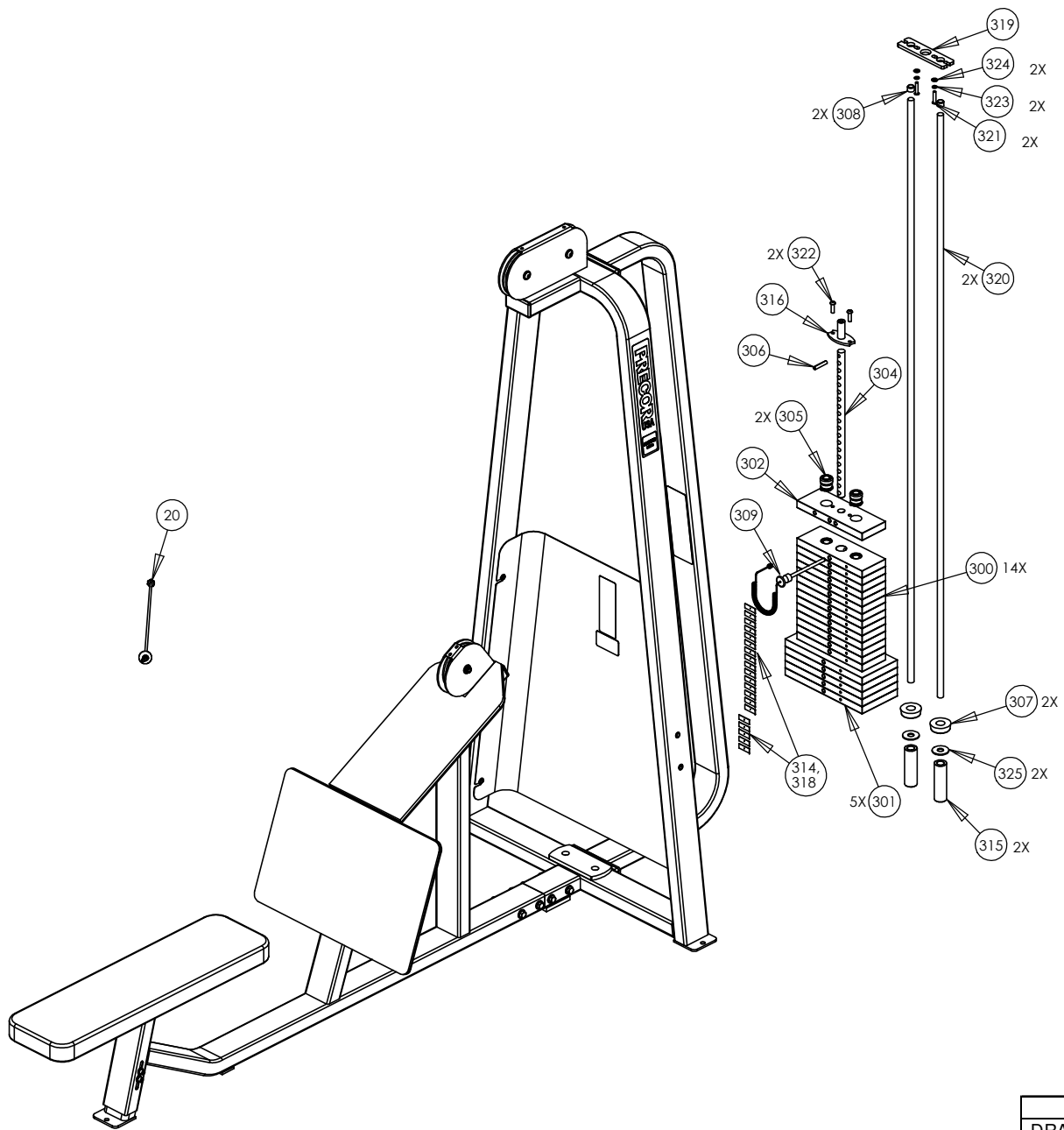

P/N: CW31931-402	SUBREV: C
DRAWN BY: JEC	DATE: 09.11.08
SHEET 4 OF 4	

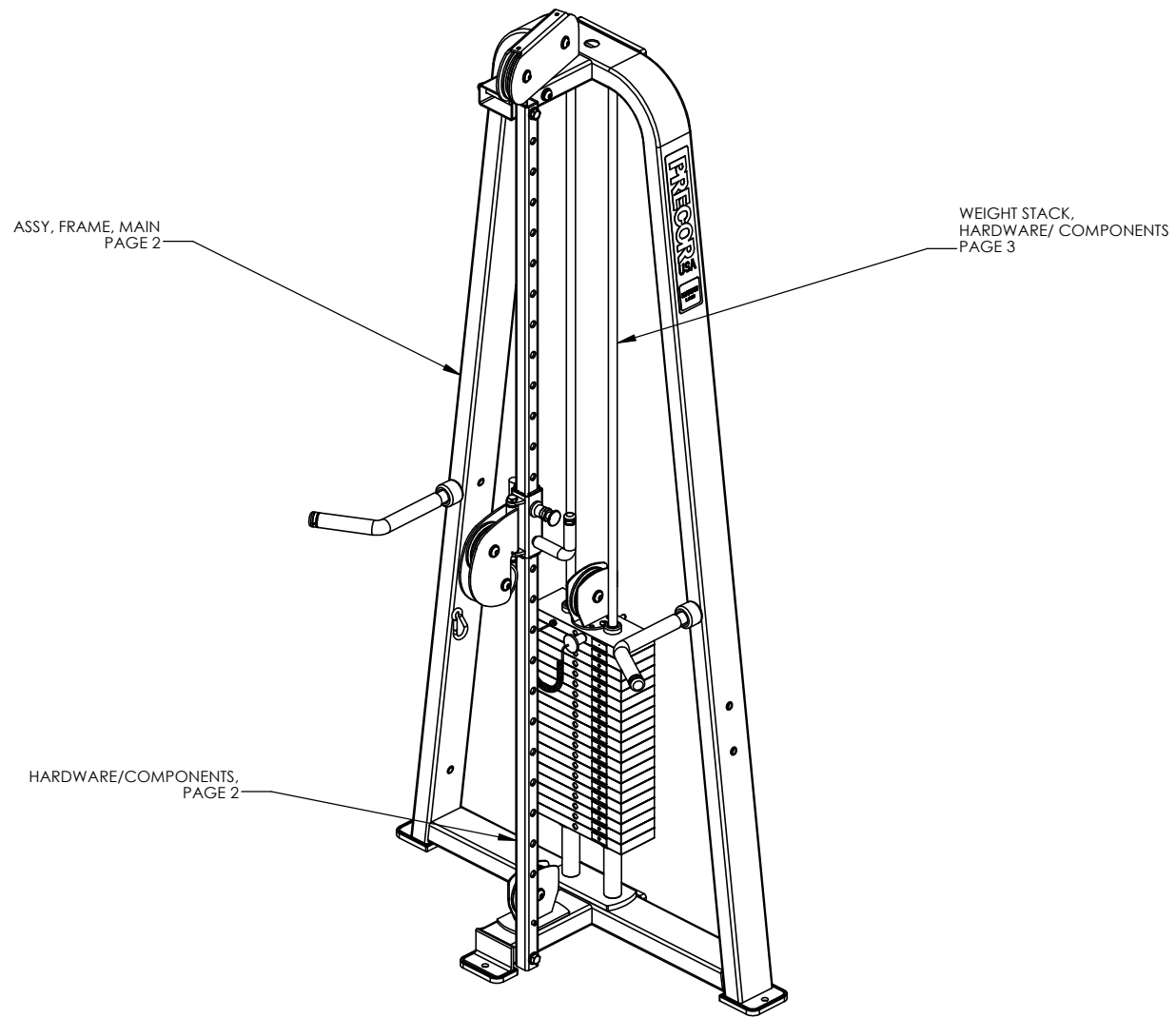

ASSY, FRAME, MAIN
PAGE 2

WEIGHT STACK,
HARDWARE/ COMPONENTS
PAGE 3

HARDWARE/COMPONENTS,
PAGE 2

P/N: CW34920-401		SUBREV: A
DRAWN BY: VLE	DATE: 06.24.09	SHEET 1 OF 3

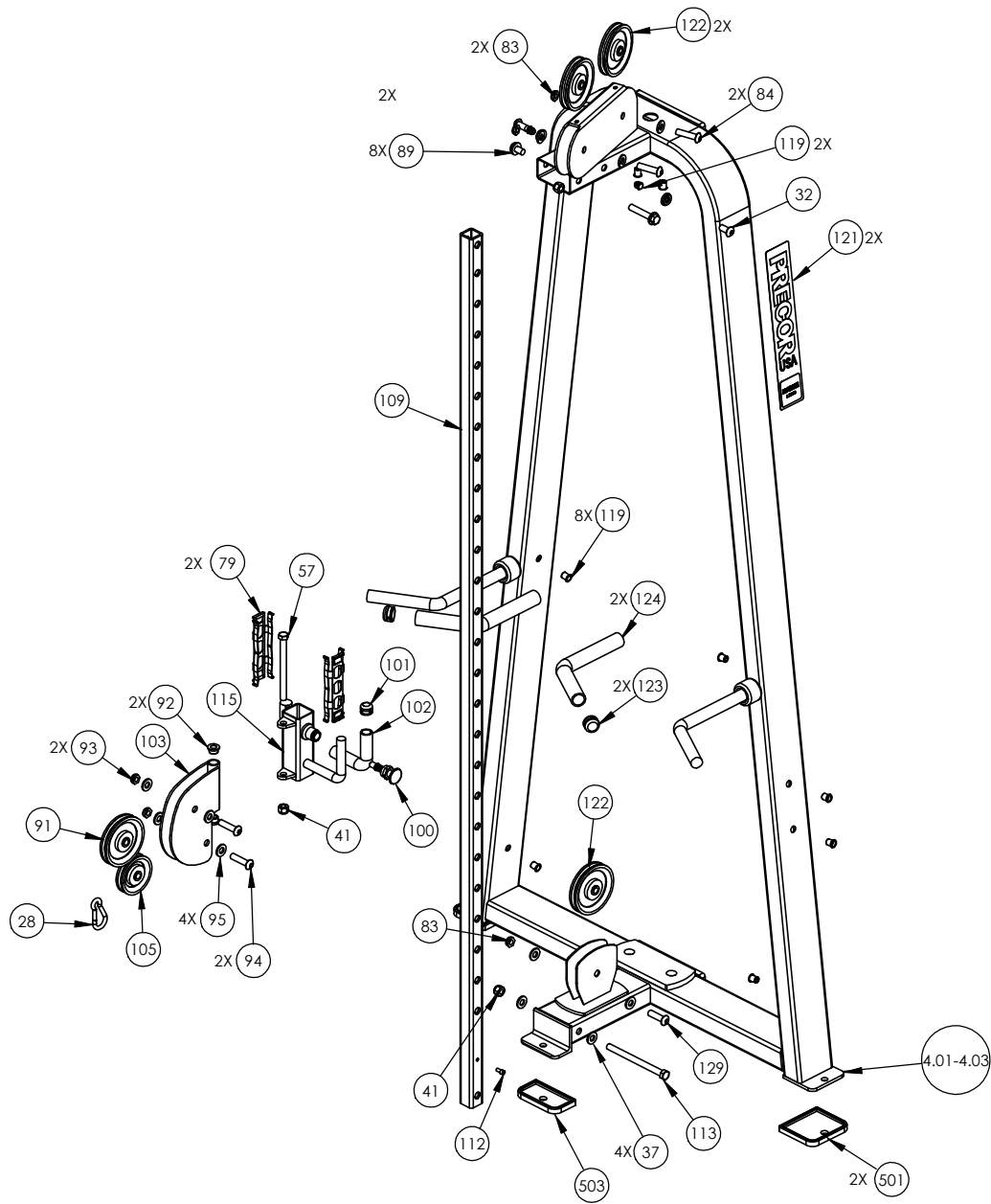

P/N: CW34920-401	SUBREV: A
DRAWN BY: VLE	DATE: 06.24.09
SHEET 2 OF 3	

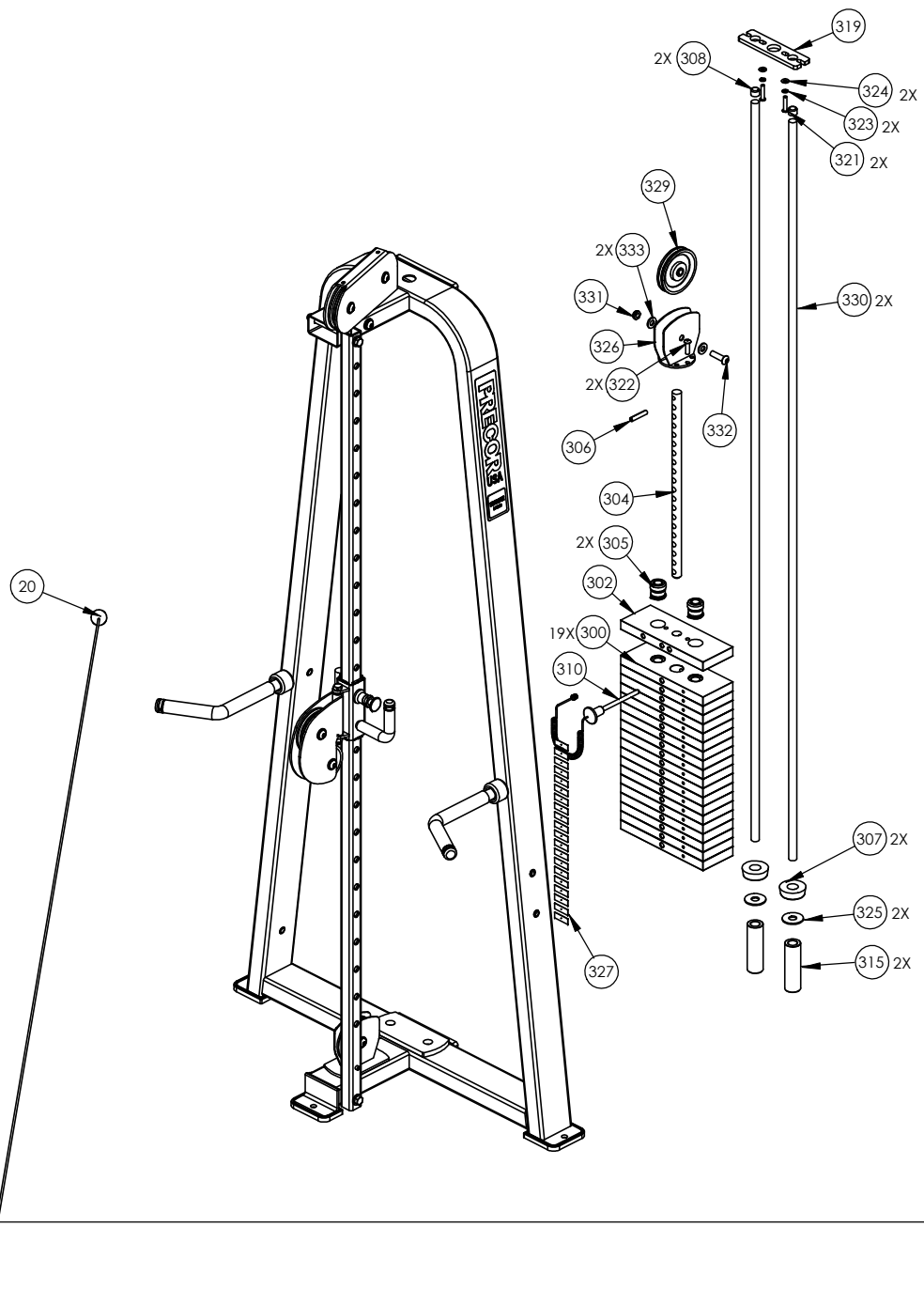

P/N: CW34920-401	SUBREV: A
DRAWN BY: VLE	DATE: 06.24.09
SHEET 3 OF 3	

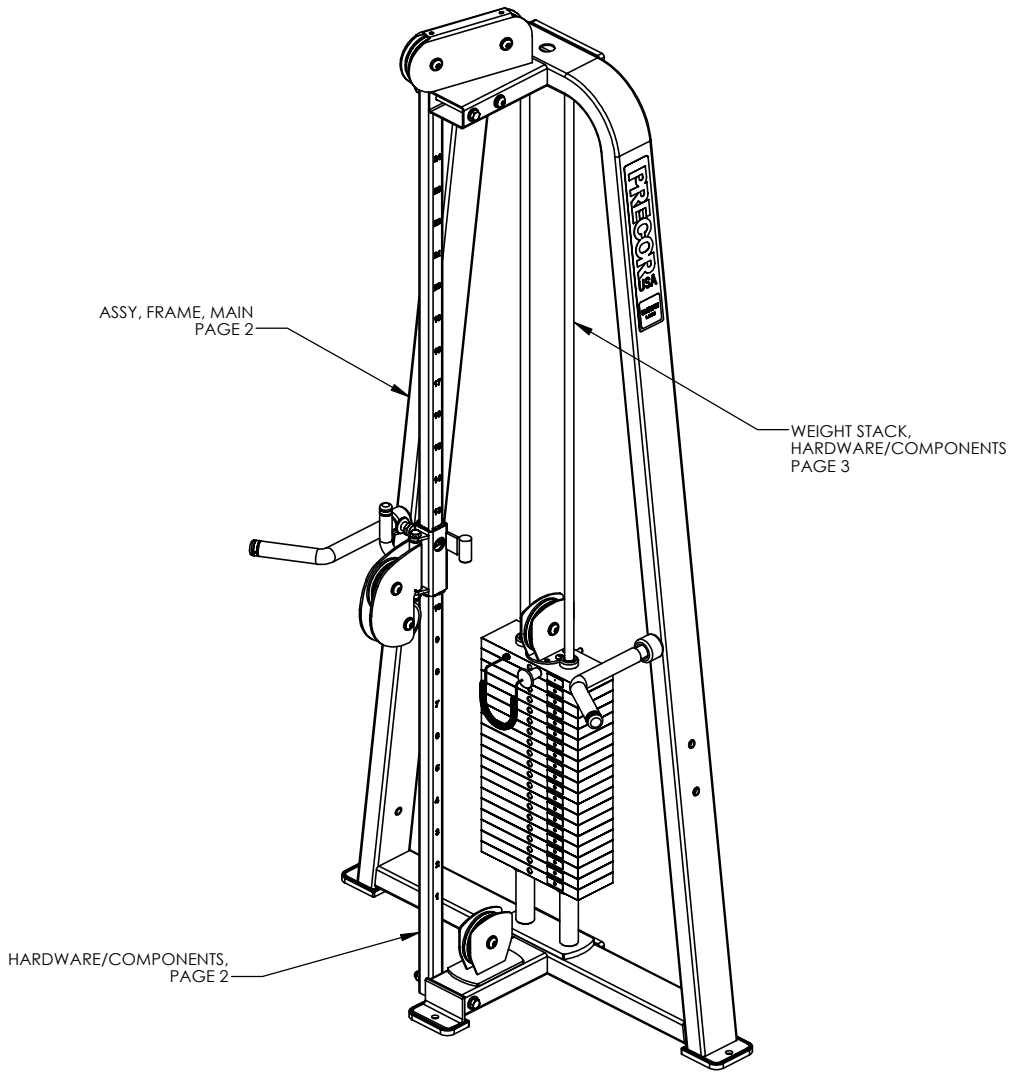

P/N: CW34921-401	SUBREV: A
DRAWN BY: VLE	DATE: 06.24.09
SHEET 1 OF 3	

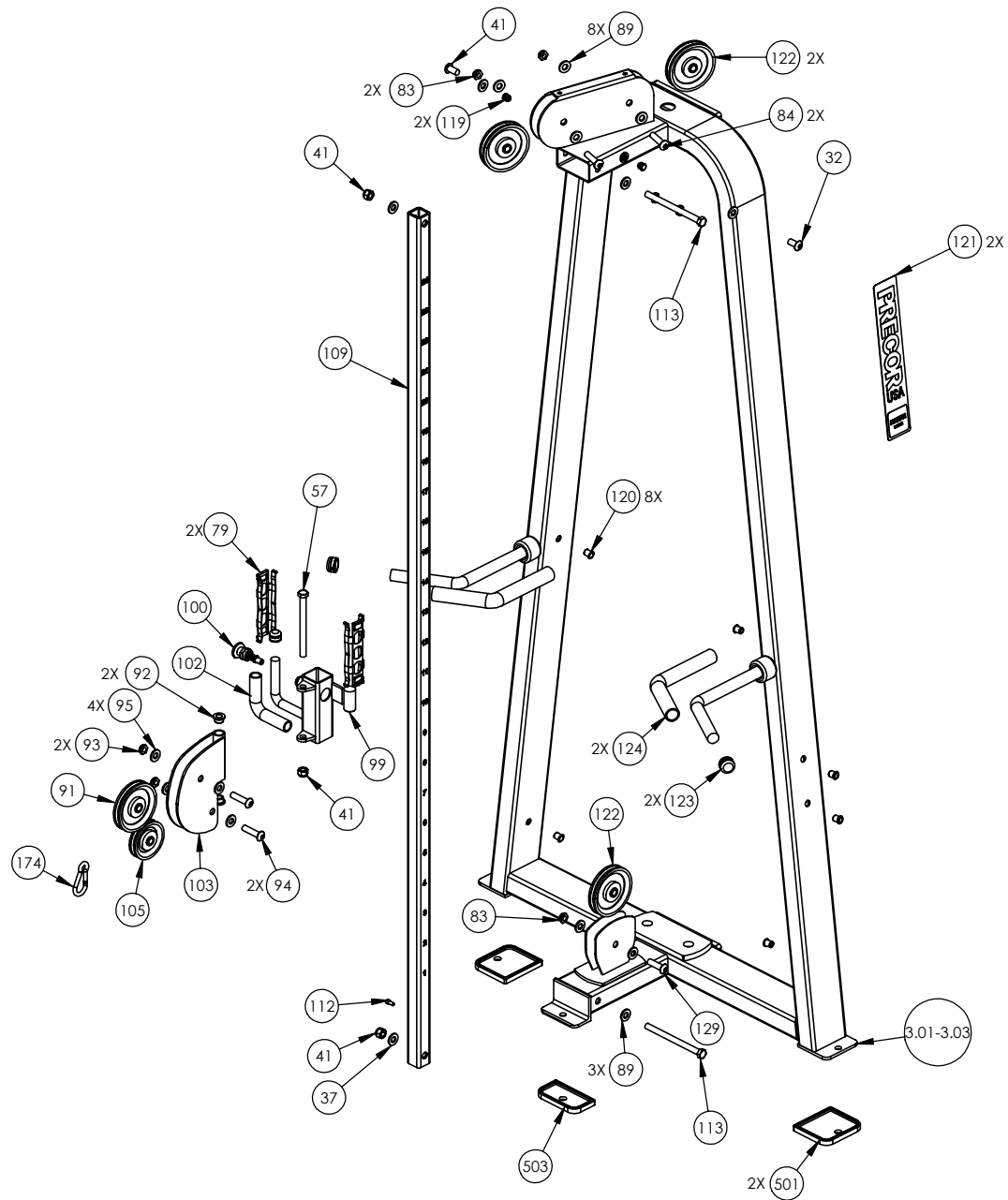

P/N: CW34921-401		SUBREV: A
DRAWN BY: VLE	DATE: 06.24.09	SHEET 2 OF 3

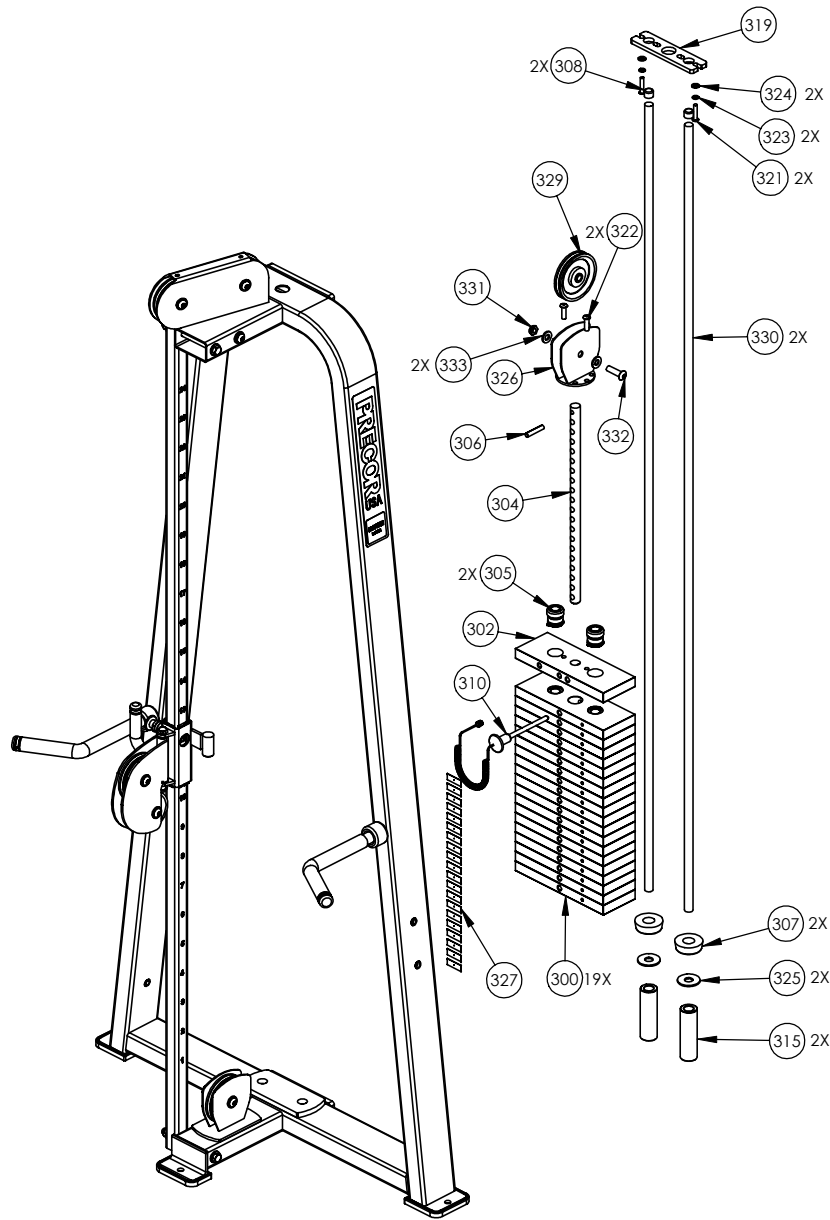

P/N: CW34921-401	SUBREV: A
DRAWN BY: VLE	DATE: 06.24.09
SHEET 3 OF 3	

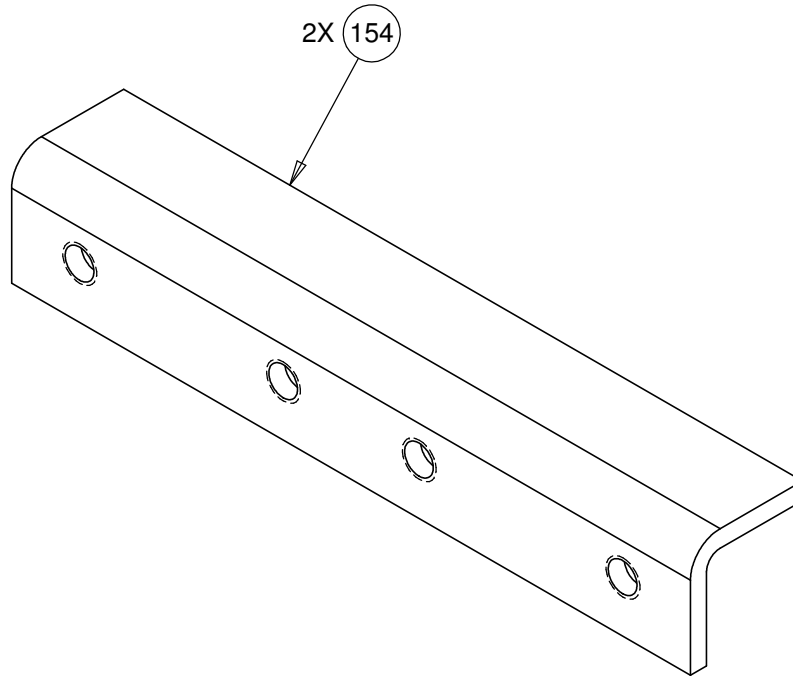

CONFIDENTIAL

THIS DOCUMENT AND INFORMATION CONTAINED HEREIN IS PROPRIETARY AND CONFIDENTIAL TO PRECOR STRENGTH INCORPORATED. RECIPIENTS OF THIS DOCUMENT AGREE THAT THIS DOCUMENT AND INFORMATION WILL NOT BE USED FOR ANY PURPOSE, REPRODUCED OR COPIED, OR DISCLOSED TO ANY THIRD PARTY, EITHER IN WHOLE OR IN PART WITHOUT PRIOR EXPRESS WRITTEN PERMISSION OF PRECOR STRENGTH INCORPORATED.

PRECOR USA
PRECOR STRENGTH, INC.

**28936 AVE WILLIAMS
VALENCIA, CA 91355
TELEPHONE: 661-362-0300**

SIGN IN BLUE OR BLACK INK ONLY			UNLESS OTHERWISE SPECIFIED: DIMENSIONS ARE IN INCHES TOLERANCES ARE: LIN .X=±0.1 .XXX=±0.010 LIN .XX=±0.02 .XXXX=±0.0001 ANGULAR: ±1.0° ALL DIMS AFTER PLATING BREAK ALL SHARP EDGES REMOVE ALL BURRS ALL ANGLES & BENDS 90° DWG PER ASME Y14.5M-1994 DO NOT SCALE DRAWING 125° ALL MACHINED SURFACES												
DRWN BY	08.27.09	VLE													
DWG CHK			<table border="1"> <tr> <td>SIZE</td> <td>PAGE</td> <td>OF</td> <td>DWG. NO.</td> <td>SUBREV</td> </tr> <tr> <td>A</td> <td>1</td> <td>1</td> <td>CW33293-402</td> <td>A</td> </tr> </table>			SIZE	PAGE	OF	DWG. NO.	SUBREV	A	1	1	CW33293-402	A
SIZE	PAGE	OF				DWG. NO.	SUBREV								
A	1	1				CW33293-402	A								
ENG	08.27.09	VLE													
MFG ENG															
CS															
QA															
ID															
REG															

PRODUCT:	STRENGTH
	STEEL, CHANNEL
DWG. NO.	SUBREV
CW33293-402	A

HANDLES/COMPONENTS
SHEET 3

CARRIAGE/SLIDES,
SHEET 3

WEIGHTS/GUIDE RODS,
SHEET 4

FRAME/C-FRAME,
SHEET 2

CW320KS	P/N: CW33596-101	SUBREV: C
DRAWN BY: JEC	DATE: 09.11.08	SHEET 1 OF 4

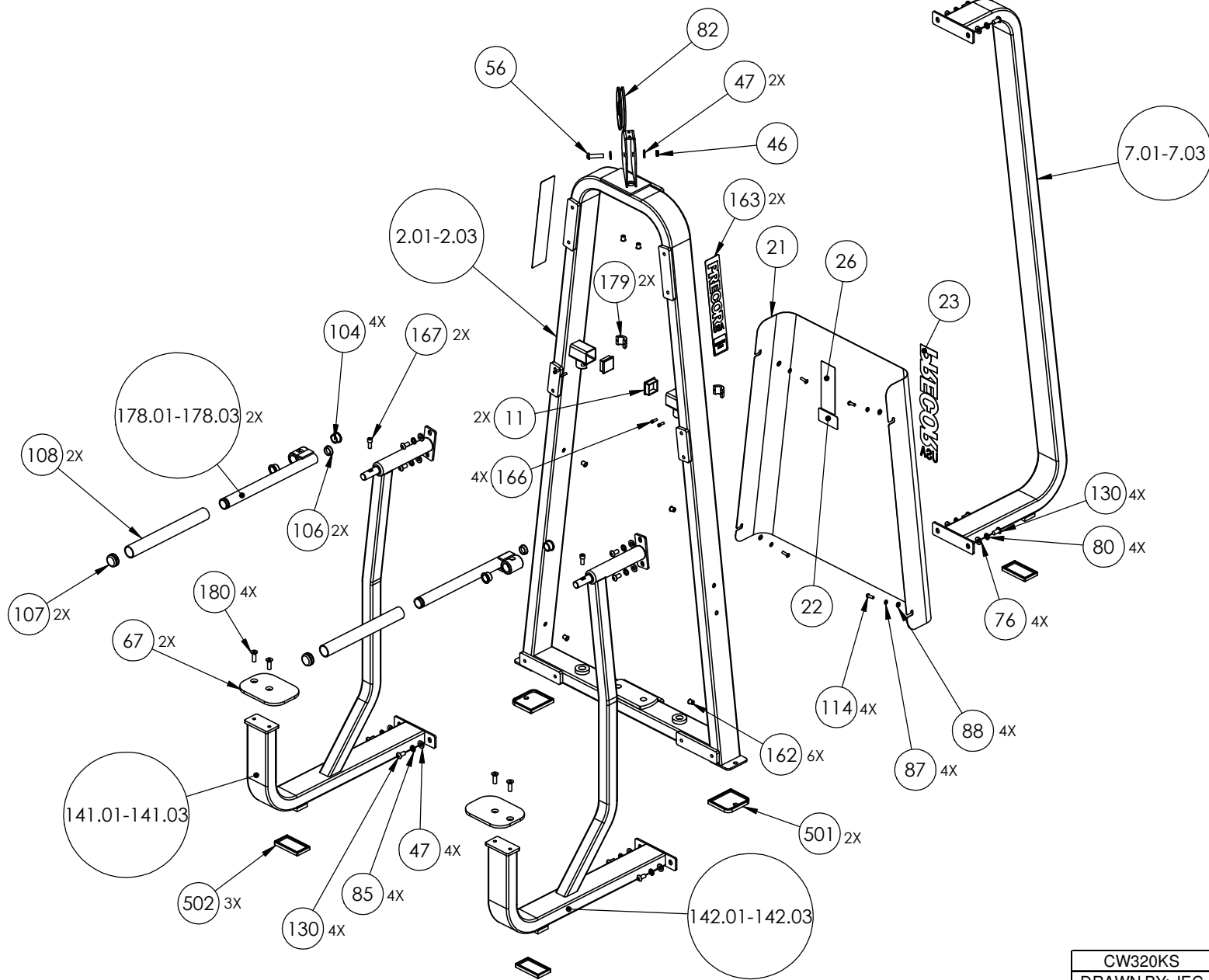

CW320KS	P/N: CW33596-101	SUBREV: C
DRAWN BY: JEC	DATE: 09.11.08	SHEET 2 OF 4

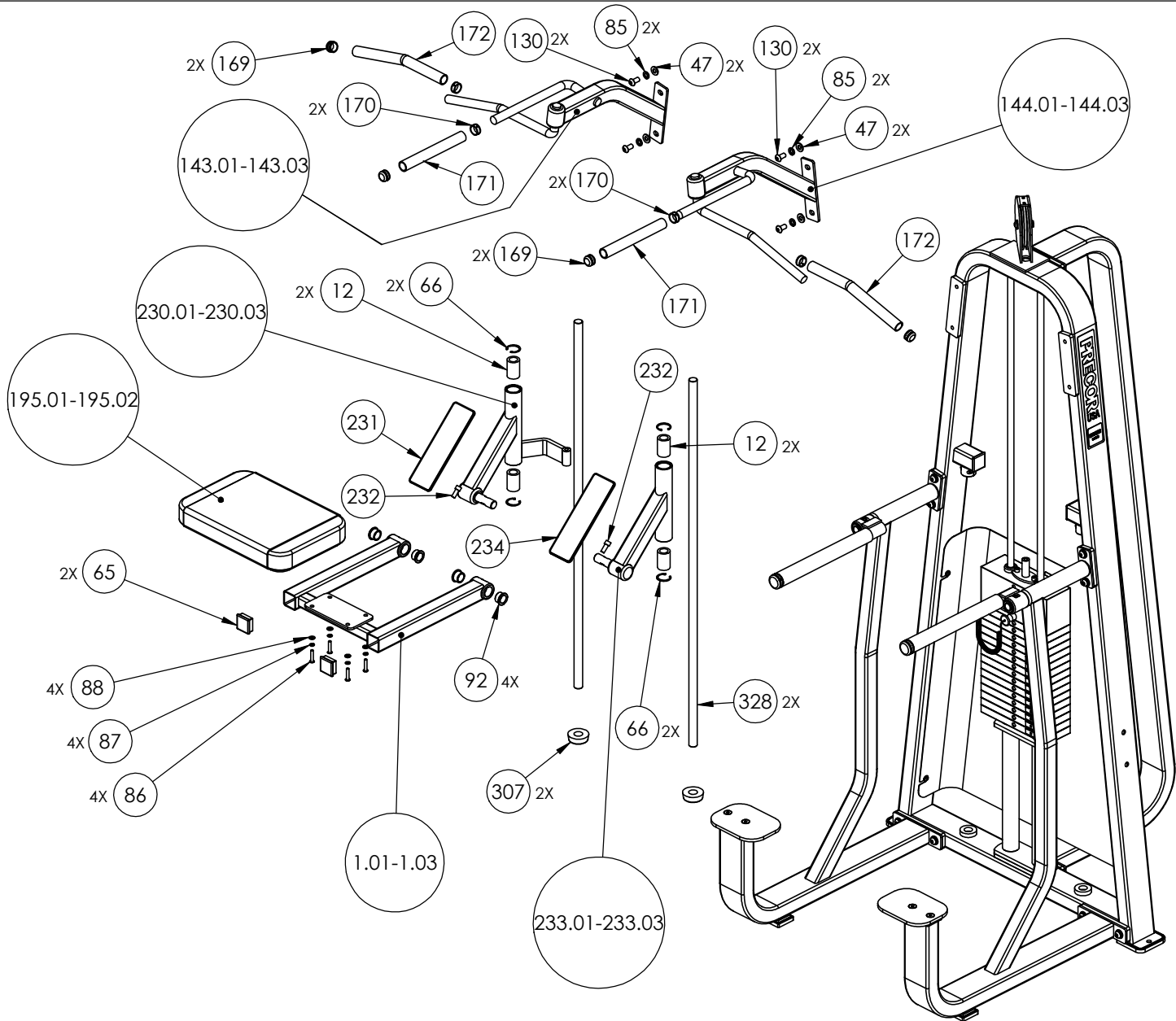

CW320KS	P/N: CW33596-101	SUBREV: C
DRAWN BY: JEC	DATE: 09.11.08	SHEET 3 OF 4

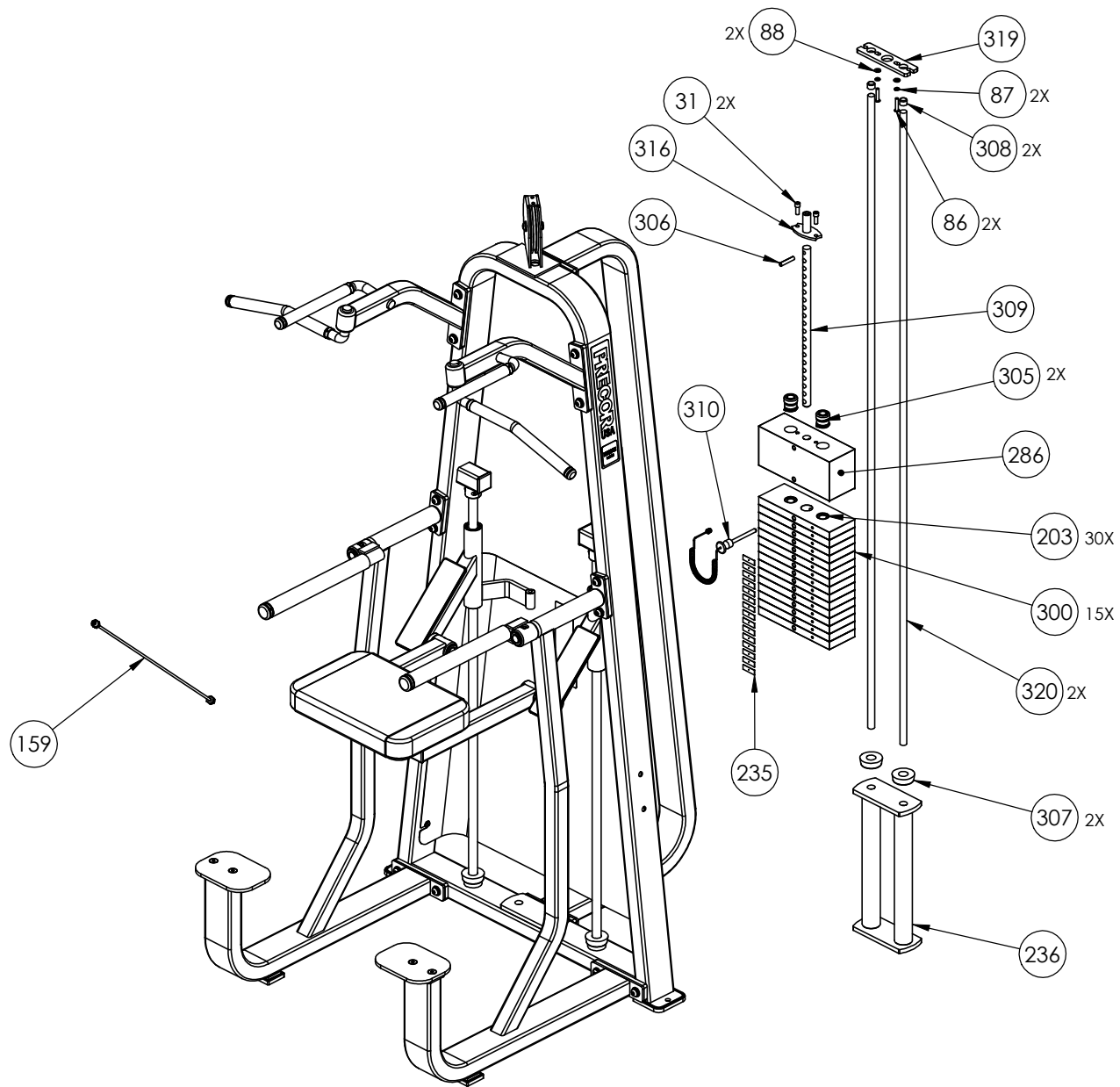

CW320KS	P/N: CW33596-101	SUBREV: C
DRAWN BY: JEC	DATE: 09.11.08	SHEET 4 OF 4